

VON NEUMANN & HARVARD

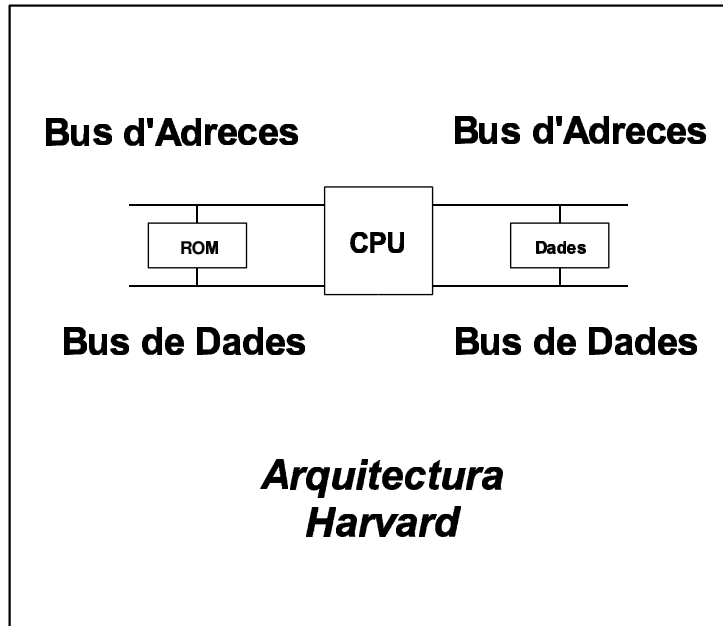

VON NEUMANN: CPU + MEMÒRIA

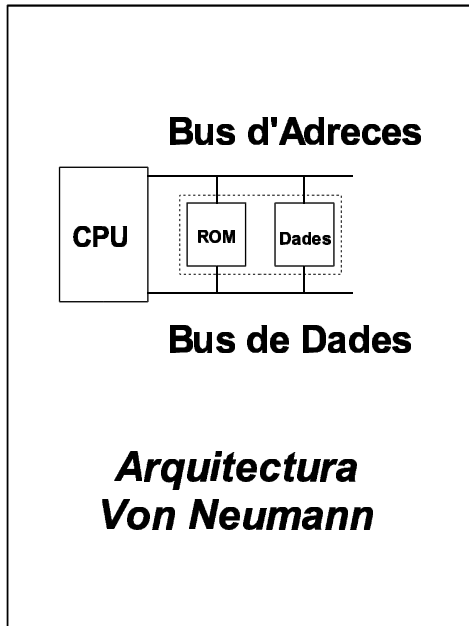
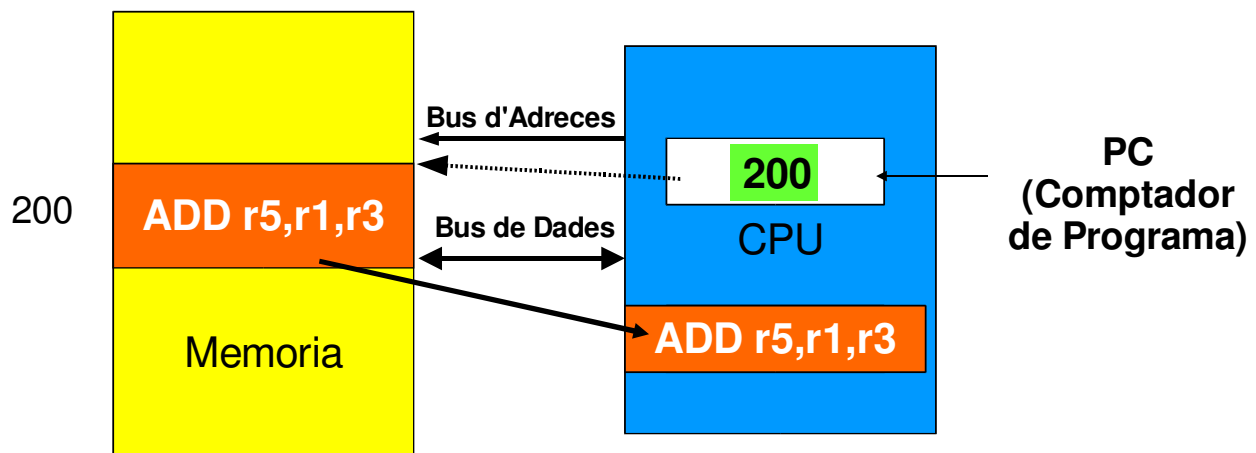

ARQUITECTURA HARDVARD

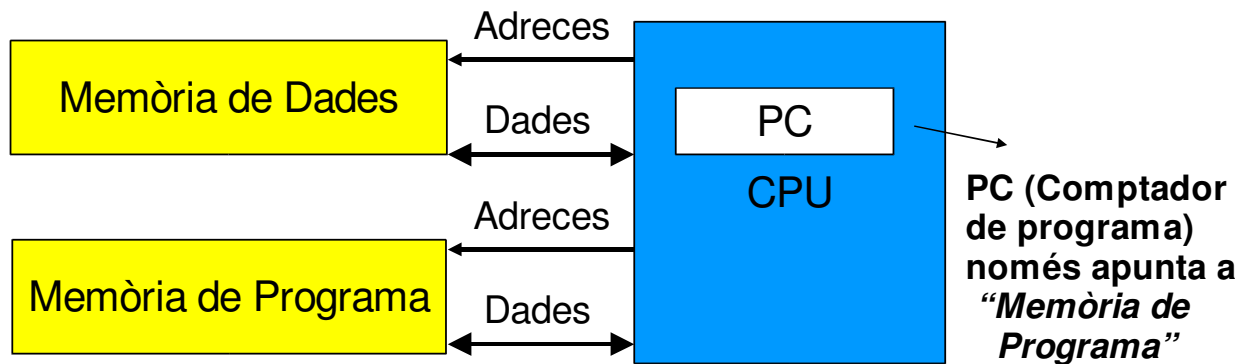

VON NEUMANN vs. HARVARD

- HARVARD permet dos accessos simultanis a memòria: PROGRAMA & DADES
- HARVARD no pot fer "automodificació" de codi
- Els DSPs utilitzen arquitectura HARVARD per tractar senyals a temps real.

VON NEUMAN: Zilog Z80

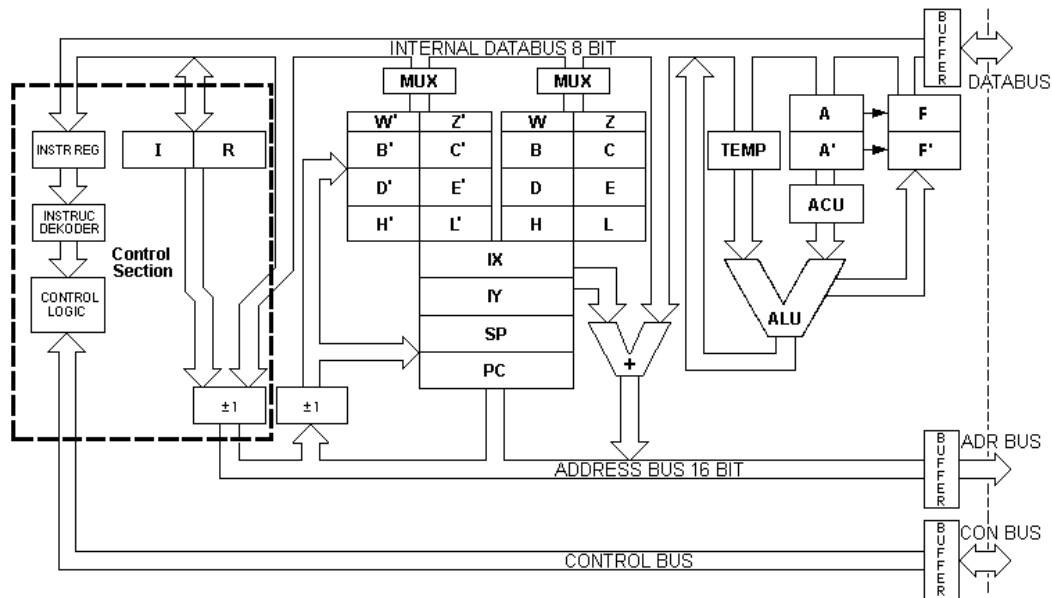

HARVARD: Microchip PIC16C8x

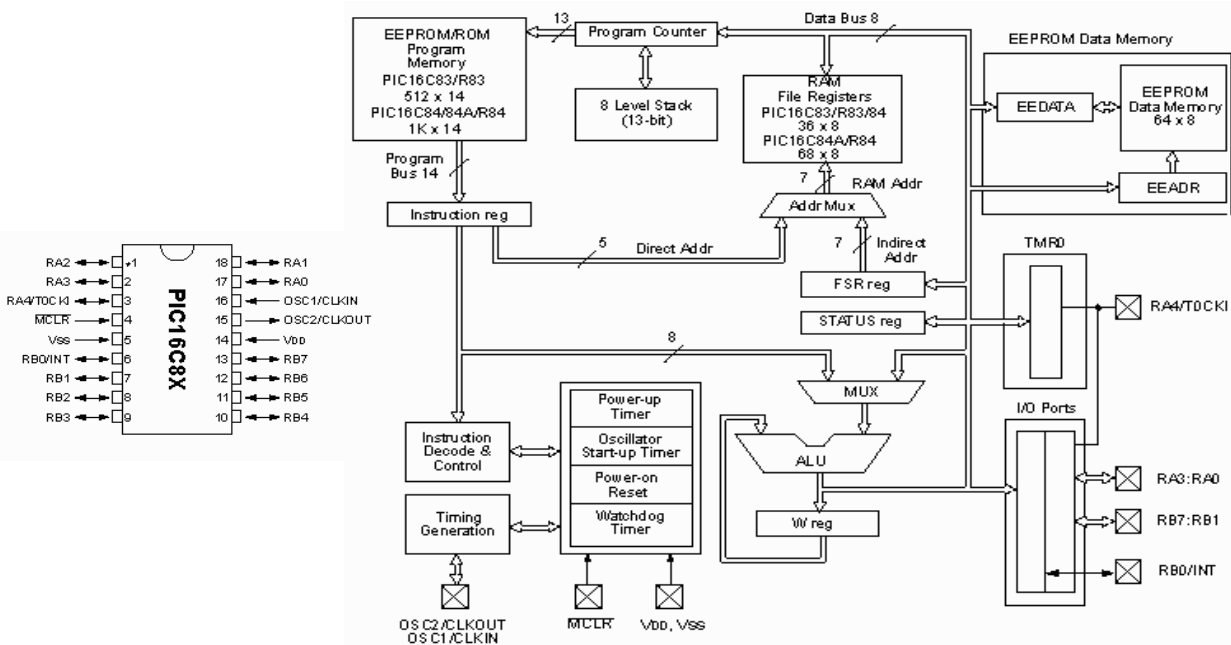

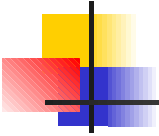

COMPARATIVA

	Von Neumann	Harvard
Format d'instrucció	Variable	Fixe
Memòria	Única	Diferenciada
La majoria	CISC	RISC
Exemples	VAX 11, MS1	PIC, DSPs